

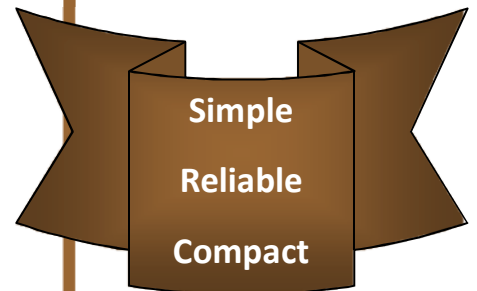

GS-90 Tamp-Blow Label Applicator

available with fixture or conveyor-mounted



So easy to operate, it is "second-shift-proof."

Please contact us today to explore the possibilities.



Star Packaging Supplies Co.

616 S. 92nd Street Milwaukee, WI 53214

Phone: 1-800-634-0901 • Email: starpkg@starpackagingsupplies.com

www.starpackagingsupplies.com



*So easy to operate,
it is "second-shift proof"*

General Description

The Gold Seal® GS-90T is a state-of-the-art compact, value-packed label applicator that's ideal for stand-alone or integrated, industrial or consumer labeling.

Key Features include:

- No operator adjustments for reliable operation
- Label sensor in strip edge, automatically adjusts to any size label
- Automatically advances if missing labels on web
- Stepper motor drive
- Tamp pad retracts upon impact
- Simple threading path

Applicator Specifications

Label dimensions:

Width: 1/2" - 5"

Length: 1/2" - 10"

Accuracy:

+ or - 1/64th" Tamp-blow

Outside Roll Diameter: 12"

Label Core Diameter: 3"

Product Sensing: Photoelectric

Label Sensing: Photoelectric

Air: 40 lbs.

Electric: 110-120 VAC

Available Options

Low Label Light Tower

Product Fixture Base

Adjustable Support Stand

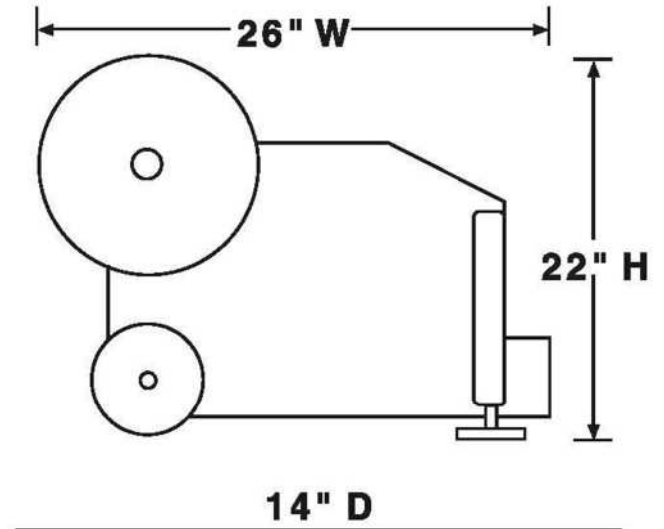

Dimensions

GS-90: 26"W x 22"H x 14"D

With fixture base: 26"W x 24-1/2"H x 22"D

With T-stand: 45"W x 54"H x 34"D



Distributed By:

Star Packaging Supplies Co.

616 S. 92nd Street Milwaukee, WI 53214

Phone 1-800-634-0901

starpkg@starpackagingsupplies.com

www.starpackagingsupplies.com